



BEACONS



Permanent Mount Only Permanent Mount Only

6465 SERIES

SAE Class III LED

ECCO's maintenance free 6465 Series LED Beacon features a Pulse8 flash pattern, producing a warning signal that is ideal for industrial-type applications. The long, maintenance-free service life of LED technology, backed by a 3-year warranty, make this a perfect replacement solution for existing strobe beacons. This cost-effective light features a wide 12-80V operating range that also makes it ideal for use on electrically-powered vehicles and equipment.

Models

PART NO.	VOLTAGE	AMPS	FPM	MOUNT
6465X	12-80	0.1	85 Pulse8	3 Bolt Flange
6465X-MG	12-80	0.1	85 Pulse8	Magnet
6465X-HBT	12-80	0.1	85 Pulse8	Semi-Permanent HBT

Replace X in part number with desired color: A=amber, B=blue, C=clear, G=green, R=red

Features and Benefits

- Pulse8 (8 flash per cycle) flash pattern
- Reinforced-nylon base and polycarbonate lens
- Rechargeable battery powered model available in all colors
- Temperature Range: -22°F to +122°F (-30°C to +50°C)

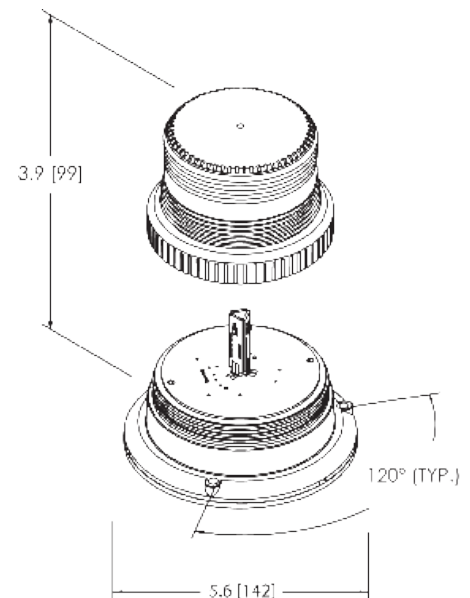

Parts & Accessories

- Lenses:
 - Amber - R6400LA
 - Blue - R6400LB
 - Clear - R6400LC
 - Green - R6400LG
 - Red - R6400LR